

HONG KONG PLANNING
STANDARDS AND GUIDELINES

Chapter

7

Utility
Services

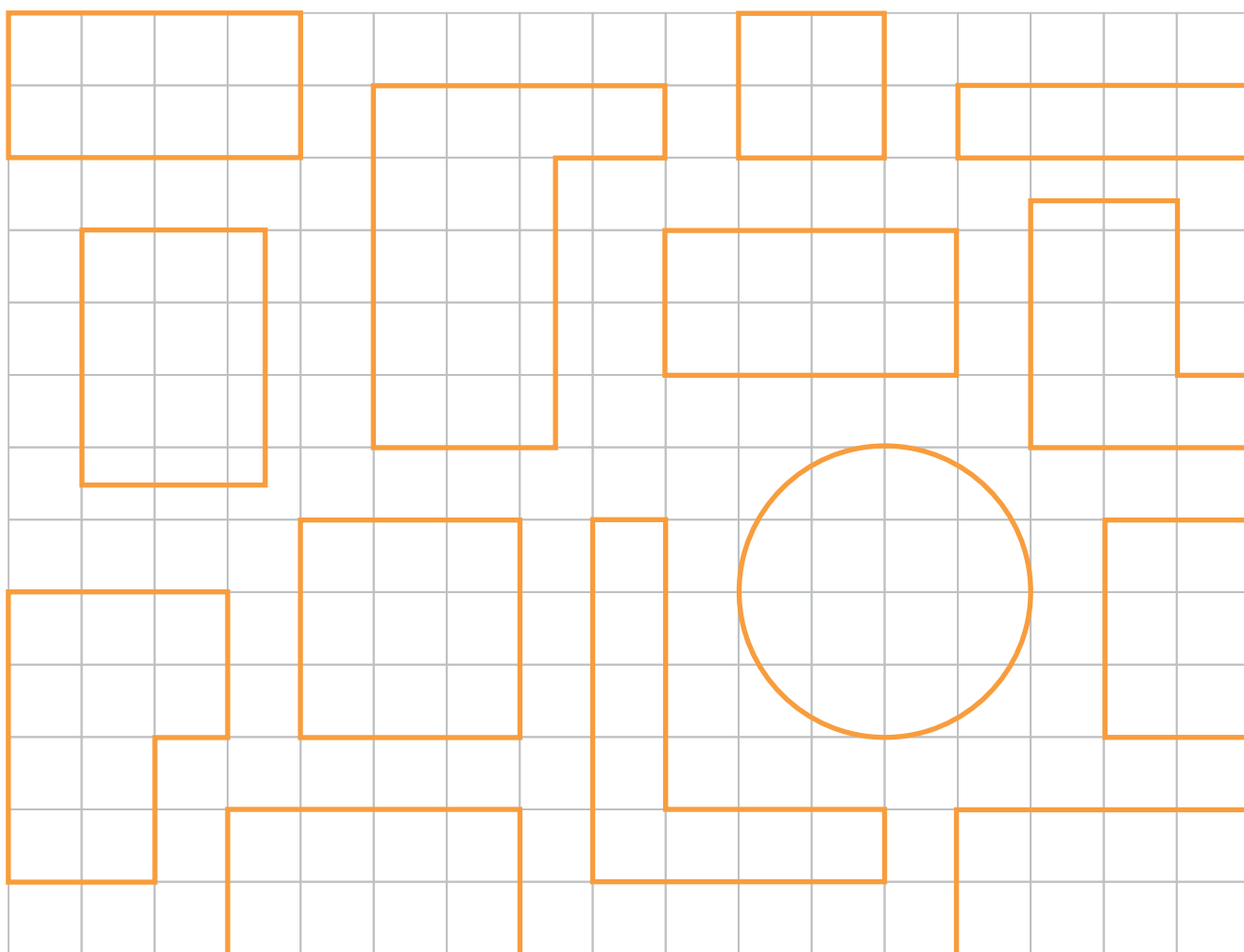

- CONTENTS -

1.	Introduction	1
2.	Electricity Supply	2
3.	Gas Supply	10
4.	Telephone Service	12
5.	Radio Telecommunications and Broadcasting Services	16
6.	Water Supply	17
7.	Drainage Services	20
8.	Dedicated Utility Reserves	22
9.	District Cooling System	22

UTILITY SERVICES

1. Introduction

- 1.1 The provision of utility services, is fundamental to modern living. From the planning point of view, these services are essential components of the basic infrastructure. The planning of their provisions should be well coordinated and integrated into the overall planning of new development areas such that a coherent and aesthetic design can be achieved. Adequate mitigation measures on building design, screening and landscaping should be incorporated to ensure that the buildings/structures of the utility installations/services could blend in with their surroundings and no unacceptable adverse environmental impacts, including visual impact, would be generated. For specific greenery coverage requirements, users may refer to Development Bureau Technical Circular (Works) No. 3/2012 – Site Coverage of Greenery for Government Building Projects or Buildings Department’s Practice Notes for Authorized Persons, Registered Structural Engineers and Registered Geotechnical Engineers APP-152 – Sustainable Building Design Guidelines, where applicable. Where landscaping (including vertical greening) is required, the size of the site would have to be suitably adjusted to cater for such requirement.
- 1.2 This chapter provides planners with the basic information on electricity supply, gas supply, telephone service, radio telecommunications and broadcasting services, water supply, drainage services and district cooling system. The guidelines would help planners understand the requirements of these services/facilities, and enable them to work with various government departments and utility companies in the planning of new development areas.
- 1.3 Where land is required for the provision of utility services, subject to safety and other necessary requirements, the general principle of maximising land use efficiency should be pursued in consultation with the relevant bureaux/departments. In particular, the following factors should be thoroughly examined during the planning process:
 - 1.3.1 The size of the buildings/structures of the utility installations should be limited to the minimum possible for meeting the development needs of the area that the concerned utility installation serves; and
 - 1.3.2 The maximum development potential of the sites identified for the concerned utility installations should be exploited as far as practicable. For example, co-location could be considered wherever possible and subject to compliance with the prevailing safety standards and other policies.

2. Electricity Supply

2.1 General

- 2.1.1 Electricity supply is currently provided by The Hongkong Electric Company Limited (HK Electric) (for Hong Kong Island and the neighbouring islands of Ap Lei Chau and Lamma) and the CLP Power Hong Kong Limited (CLP Power) (for the whole of Kowloon, the New Territories and a number of outlying islands including Lantau).
- 2.1.2 Electricity supply facilities include power generating stations, electric substations, overhead lines and underground/submarine cables. Only the latter three items are discussed because power generating stations are major territorial facilities requiring special investigations on each project.

2.2 Electric Substations

- 2.2.1 Electricity is transmitted and distributed by different types of electric substations. The CLP Power network includes extra high voltage (EHV) substations, bulk infeed substations (BISs), primary substations and consumer substations. The HK Electric network includes bulk infeed substations, primary substations and consumer substations. The substations' characteristics are discussed below:

(a) *Extra High Voltage Substations & Bulk Infeed Substations (Switching Stations)*

In the CLP Power network, the EHV substations receive power from the power stations or from other EHV substations at 400 kilovolt (kV) and supply the bulk infeed or primary substations at 132kV. BISs receive power from EHV substations or other BISs at 132kV and supply the primary substations at voltages ranging from 33kV to 132kV and consumer substations at 11kV. In The HK Electric network, BIS receive power from the power stations or from other BISs at 275kV or 132kV and supply the primary substations at voltage of 132kV to 275kV.

(b) *Primary Substations (Zone Substations)*

In general, for the CLP Power network, primary substations receive electric power at voltage of 33kV up to 132kV and supply all the 11kV loads in the supply area. For The HK Electric network, in general primary substations receive electric power at voltage of 132kV to 275kV and supply all the 22kV and 11kV loads in the supply area.

(c) *Consumer Substations (Distribution Substations)*

Consumer substations for CLP Power network receive power at a voltage of 11kV and deliver it at 380V. Consumer substations for The HK Electric network receive power at a voltage of 22kV or 11kV and deliver it at 380V. There are two types of consumer's substations:

- (i) Indoor Type (Transformer Room)
This is normally provided within the consumers' premises.
- (ii) Outdoor Type
This is mainly found in rural development areas and may be located either inside or outside the consumers' premises.

2.2.2 Sufficient number of primary substations and BISs are required to meet all the 22kV and 11kV loads in a supply area. In order to meet the demand for electricity supply in a new town or re-developed area on time, it is recommended that the relevant utility company be advised of the scale of development at an early planning stage. CLP Power or HK Electric will investigate if demand can be met by the existing primary substations and BISs, or new ones are required. With respect to the access, parking and loading/unloading arrangements, Transport Department should be consulted at an early planning stage. Please refer to Table 11 of Chapter 8 for parking and loading/unloading requirements.

Guidelines on Provision

2.2.3 *Extra High Voltage Substations & Bulk Infeed Substations (Switching Stations)*

- (a) These stations should be located near to the pylons of transmission lines or major transmission cable routes (for BIS) in the vicinity of the supply area and in an area which permits adequate cabling in the access road(s) leading to the substations.
- (b) They should be at least 200m away from the nearest fence of any telephone exchange, radio-communications and broadcasting installations. Additional advice should be obtained from the Director-General of Communications (DG, Office of the Communications Authority (OFCA)).
- (c) As a major electric substation will be a major source of noise nuisance, it should be located away from residential or other sensitive uses wherever possible to minimize any noise problems. If this is not feasible, suitable noise control measures will need to be included in the design of the station (section 4.2.13 of Chapter 9).
- (d) The separation from other buildings/structures should be at least 6m.
- (e) Except with prior approval of the Director of Fire Services (D of FS), no domestic units should be provided above substations.
- (f) The site requirement for a typical EHV substation (with 6 x 240 MVA (Mega Volt-amp), 400kV transformers) is about 6 500m² (100m x 65m). Free access via a carriageway of width not less than 7.3m is required and the gradient should not exceed 1 in 12. These figures are for reference only as each site reservation is subject to detailed examination. Additional advice should be obtained from the Director of Electrical and Mechanical Services (DEMS).

- (g) The site requirement for a typical BIS in the CLP Power network (with 4 x 50 MVA, 132/11kV transformers, and 132kV switchboard) is about 2 870m² (70m x 41m). In The HK Electric network, the site requirement for a typical BIS is between 1 504m² (32m x 47m for a switching station at 275/132kV level) and 2 550m² (30m x 85m for a switching station at 275/132kV level with 2 x 300MVA 275/132kV transformers). Free access via a carriageway of not less than 7.3m wide and with a gradient not exceeding 1 in 10 is required. These figures are again for reference only and individual site is subject to detailed assessment on a case by case basis. Additional advice can be obtained from the DEMS.

2.2.4 *Primary Substations (Zone Substations)*

- (a) They should be located as near as possible to the supply area and should be adjacent to more than one road to allow for adequate cabling requirement.
- (b) They should be at least 200m away from the nearest fence of any telephone exchange, radio-communications and broadcasting installations. Additional advice can be obtained from the DG, OFCA.
- (c) Except with prior approval of the D of FS, no domestic units should be provided above the substation.
- (d) The site requirement for a typical primary substation in the CLP Power network (with 4 x 50 MVA, 132/11kV transformers, 132kV RMUs and 80 x 11kV switchgear panels) is about 1 705m² (55m x 31m). The site requirement for a typical primary substation in The HK Electric network, with 4 x 60 MVA, 275 or 132kV transformers is about 1 600m² (40m x 40m). The depth of the building should be increased by 11m for each additional transformer to be installed. Free access via a carriageway of not less than 7.3m wide with a gradient not exceeding 1 in 10 is required. The figures are again for reference only. Additional advice can be obtained from the DEMS.

2.2.5 *Consumer Substations (Distribution Substations)*

- (a) Indoor Type (Transformer Room)
As this is normally provided within the consumer's premises, the siting of the facility would be taken up with individual developer with the power utilities concerned.
- (b) Outdoor Type
 - (i) It should be located as near as possible to the area it serves.
 - (ii) Adjacent buildings or structures should have a minimum fire resistance rating of 2 hours failing which a physical separation of at least 3m should be allowed for.

- (c) The typical substation size for housing a 1.5 MVA, 22kV or 11kV transformer and associated control gear is 30.25m² (5.5m x 5.5m) for outdoor type and 51m² (8.5m x 6m) for indoor type.
- (d) Access road with a width of not less than 3m is required.

2.3 Overhead Transmission Lines

Guidelines on Provision

- 2.3.1 The location of new pylons and overhead transmission lines (OHL) should not be permitted to dictate the pattern of future land use or to sterilize land which has a good development potential. If the land is required for development, the existing transmission lines, unless part of an approved scheme which is the subject of an order under the Electricity Networks (Statutory Easements) Ordinance, may have to be relaid underground or re-routed. However, the high cost involved in diversion should be given due consideration.
- 2.3.2 They should not be erected in existing developed areas, areas having substantial development potential, and public open space, as far as practicable. Except in very special circumstances, environmentally sensitive areas such as Sites of Special Scientific Interest (SSSI), conservation areas and country parks should also be avoided.
- 2.3.3 Early consultation with the concerned departments at the planning stage is essential, particularly on matters relating to locations of pylons and OHLs. For extra high voltage transmission lines e.g. 400 kV, detailed site search reports with full justifications should be prepared for consideration of relevant departments.

Environmental Considerations

- 2.3.4 When the erection of permanent OHLs and pylons is planned, a prudent approach should be adopted taking into account the following principles and environmental considerations:
 - (a) They should be routed to avoid as far as practicable, residential areas and environmentally sensitive areas such as SSSI, conservation areas, country parks, ridgelines or locations which will seriously affect the view from major residential developments.
 - (b) The location and design of pylons should minimize the ecological and visual impacts on the landscape and nearby residential developments.
 - (c) Damage to existing vegetation through the erection of pylons should be minimized and landscape reinstatement should be undertaken where necessary.

- (d) Where permanent overhead lines in environmentally sensitive areas covered by para. (a) cannot be avoided, the Director of Agriculture and Fisheries (where the development is within a country park), the Director of Planning and the Director of Environmental Protection should be consulted to determine the appropriate type of planning and environmental assessment studies to be undertaken and whether mitigation measures should be implemented to minimize any adverse impacts identified. The Director of Home Affairs should also be consulted on the appropriate level and means of public consultation which may need to be carried out.
- (e) For OHLs which are considered as Designated Projects⁽¹⁾ under the Environmental Impact Assessment Ordinance (EIA Ordinance), the statutory EIA process must be followed and environmental permits are required for their construction and operation.

Safety Considerations

2.3.5 For electrical safety considerations, provision should be made for physical separation between conductors and adjacent buildings/structures. Depending on the design of the structures supporting the conductors, the safe working clearance should take the magnitude of swing of conductors due to wind deflection into account. The respective minimum safe working clearances for various voltage levels of conductors (except 275kV and 22kV which are conducted by underground cables) are given in Table 1.

Table 1 : Minimum Safe Working Clearance for Electrical Safety Consideration

Voltage Level (kV)	Minimum Safe Working Clearance (m)
400	5.5
132	3.7
33	2.8
11	2.8

⁽¹⁾ Designated Projects: According to Items H.1 and Q.1 of Schedule 2 of the EIA Ordinance, transmission lines of 400kV in any location, or more than 66kV if they are within environmentally sensitive areas, are considered as Designated Projects.

2.3.6 Moreover, in the design of OHLs, adequate vertical ground clearance, which is measured from the lowest point of the conductors (sagged point due to gravity) to the ground level, should be provided. The determination of the minimum vertical ground clearance should take the statutory requirements as laid down in the Electricity Supply Regulations into account. The respective figures for various voltage levels are given in Table 2.

Table 2 : Minimum Vertical Ground Clearance for Electrical Safety Consideration

Voltage Level (kV)	Minimum Vertical Ground Clearance (m)
400	7.6
132	6.7
33	6.1
11	6.1

2.3.7 The figures given in Tables 1 & 2 are for general reference purpose. To prevent confusion and possible misinterpretation of the data, early consultation with the power company and the Electrical and Mechanical Services Department (EMSD) will be necessary for their application. Additional allowance for the safety clearance may be required by the EMSD to suit the actual site conditions.

2.3.8 In addition to the minimum safety clearance, allowance for the provision of a 6m emergency vehicular access may be required, for fire fighting purposes, to reach the principal face of any adjacent building development. Since each case will be considered on its merits, consultation with the D of FS will be required regarding the detailed arrangement.

2.3.9 To illustrate the above requirements, schematic drawings for 400kV and 132kV OHLs supported on pylon are given in Figures 1, 2, 3 and 4 respectively.

Health Considerations

2.3.10 The electric and magnetic fields (EMF) emanating from local OHLs are at extremely low frequency (50Hz) known as power frequency EMF. The EMF exposure limit promulgated in the guidelines issued by the International Commission on Non-ionizing Radiation Protection (ICNIRP)⁽²⁾ in 1998 are generally adopted as a prudent avoidance against the influence of power frequency EMF. Although there is no conclusive scientific evidence to date to support the hypothesis of adverse health effects arising from exposure to power frequency EMF below the limits set by the above ICNIRP Guidelines issued in 1998, the development and research carried out on the subject are closely monitored by departments concerned and the power companies.

2.3.11 In line with the guidelines issued by ICNIRP in 1998, the following standards on the continuous public exposure limits for power frequency electric and magnetic fields are recommended to the power companies by EMSD when the erection of permanent overhead transmission lines is planned:

- (a) The electric field strength⁽³⁾ should not exceed 5kV per metre (r.m.s.); and
- (b) The magnetic flux density⁽⁴⁾ should not exceed 0.1 millitesla (r.m.s.) (i.e. 100 microteslas, r.m.s.).

The power companies should seek further advice from the EMSD at the design and planning stages of the overhead lines concerned.

2.3.12 In general, the physical separation provided by the preferred working corridor (para. 2.3.13 refers) has made allowance for the above consideration. However, at the early planning stage of the OHLs, the power company concerned should provide the necessary information to the EMSD for consideration.

Preferred Working Corridor of Overhead Transmission Lines

2.3.13 For route protection and to provide sufficient space for pylon erection, operation, inspection, maintenance, repair, renewal and removal of the equipment, a “preferred working corridor” (as shown in Figure 1 and Figure 3) following the alignment of the OHLs, will be required for general planning purpose. In the case of pole lines, in addition to the “preferred working corridor”, a “preferred working circle” is required for pole erection as shown in Figure 5 and Figure 6.

2.3.14 The respective width of the preferred working corridor for 400kV and 132kV OHLs supported on pylons are given in Table 3 and Figure 1 and Figure 3.

(2) ICNIRP: The International Commission on Non-ionizing Radiation Protection (ICNIRP) was established in 1992 as a successor to the International Non-ionizing Radiation Committee of International Radiation Protection Association (INIRC/IRPA). The functions of the Commission are to investigate the hazards that may be associated with the different forms of the non-ionizing radiation, develop international guidelines on non-ionizing radiation limits, and deal with all aspects of non-ionizing radiation protection.

(3) Electric Field Strength: This is the force exerted by an electric field on a medium. Its magnitude is directly proportional to the voltage of the source and diminishes with distance away from the voltage source. The electric field strength is expressed in terms of volts per metre or kilovolts per metre.

(4) Magnetic Flux Density: This is the magnetic flux per unit area at a point in a magnetic field. Magnetic flux is produced by electric current passing through a wire. Its magnitude is directly proportional to the current and diminishes with distance away from the current source. The unit of the magnetic flux density is microteslas or milliteslas.

Table 3 : Preferred Working Corridor for 400kV and 132kV OHLs supported on Pylon

Voltage Level (kV)	Width of the Preferred Working Corridor (m)
400	50
132	36

Note: Some of the 132kV OHLs are supported on pylons

- 2.3.15 For conductors supported on poles, e.g. voltage level from 132kV downwards, in addition to the preferred working corridor, space is needed as a “preferred working circle” to facilitate pole erection. The height of the pole has been taken into account in determining the radius of the circle. In general, the alignment of OHLs and the location of the supporting poles should avoid existing settlements as far as possible. The respective figures of preferred working corridor and working circle for 132kV, 33kV and 11kV OHLs supported on poles are given in Table 4.

Table 4 : Preferred Working Circle and Working Corridor for Conductors Supported on Pole

Voltage Level (kV)	Width of the preferred working circle to facilitate pole erection (m)	Width of the preferred working corridor (m)
132	36	21.4
33	24	12
11	24	10

- 2.3.16 Schematic drawings for 132kV OHLs supported on poles are given in Figure 5 and Figure 6.
- 2.3.17 Building developments will not be restricted in areas outside the preferred working corridor and working circle subject to the provision of emergency vehicular access, wherever appropriate, as required by Fire Services Department (FSD). For development within the preferred working corridor and working circle, agreement from EMSD, FSD and the power company should be sought in order to ensure compliance of the safety and health considerations as given above.

- 2.3.18 For example, New Territories Exempted House/village house development underneath 400kV OHLs will be possible provided that the height of the conductors (sagged portion) is designed not less than 15.6m above the ground level. This clearance makes allowance for the maximum height of the village house (8.23m) and the average height of an antenna (1.87m) such that the minimum safety clearance of 5.5m between antenna and the 400kV conductors is maintained. However, agreement must be obtained from EMSD, FSD and the power company before the commencement of any development or building works. An illustrative sketch is given in Figure 7.
- 2.3.19 Notwithstanding the above, the Land Authority should also notify the power company concerned of any development (permanent or temporary) that is proposed within a distance of 45m from overhead transmission lines.

Separation from Telecommunication Lines on support

- 2.3.20 The alignment of the OHL should be separated from other telecommunication lines e.g. telephone, on support. Reference should be made to the “Code of Practice - Protection of Communication Networks From Electrical Power Distribution” issued by the DG, OFCA.

2.4 Underground/Submarine Cables

- 2.4.1 Cables are normally laid directly underground or under seabed, subject to permission from the Highways Department and/or the Lands Department and other appropriate authorities if required and compliance with relevant Ordinances.
- 2.4.2 Minimum separation between power cables and telephone cables is 0.3m wherever practicable. Details can be obtained from the DG, OFCA.

3. Gas Supply

3.1 General

- 3.1.1 The Government’s policy is to ensure, as far as possible, the provision of a piped gas supply to domestic consumers, particularly to new building developments, as a means of discouraging the future growth of liquefied petroleum gas cylinders. In this regard, a piped gas supply in the form of town/natural gas or from a bulk liquefied petroleum gas (LPG) storage installation should be planned for all new developments.
- 3.1.2 The Gas Safety Ordinance (Cap. 51) and its subsidiary regulations which became effective on the 1st April 1991 must be complied with when a gas supply is considered.

3.2 Piped Gas Supply

3.2.1 A piped gas supply can be made available by:

- (a) the provision of town/natural gas through the conventional reticulated supply system of the Hong Kong and China Gas Co. Ltd.;
- (b) the supply of LPG from a centralized LPG storage facility located nearby or within the development area to be served. The size of the development area can range from a large housing estate such as Mei Foo Sun Chuen to a single house; and
- (c) a form of substitute town/natural gas supplied by the Hong Kong and China Gas Co. Ltd. through a reticulated supply system from temporary LPG/air mix plants. When town/natural gas becomes available, the LPG/air mix plant would cease operation. The town/natural gas would then be supplied to consumers through the reticulated supply system in existence.

3.2.2 The advice of either the Hong Kong and China Gas Co. Ltd. (for town/natural gas) or the potential LPG supplier (for LPG) should be sought at the earliest possible stage in the design of the development or redevelopment proposals.

3.3 Guidelines on Provision

Town/Natural Gas

3.3.1 The production, storage and distribution of town/natural gas require the building of gas works, gas holder stations, pressure reduction equipment and a pigging system ranging from high to low supply pressures. Gas works and gas holder stations are very specialized facilities and need to be dealt with on an individual basis, taking account of hazard assessments. Gas pressure reduction station installations are required for reducing the pressure from a higher pressure pipeline system to a lower pressure system. The site area required for installing the pressure reduction equipment is dependent on operation requirements and can vary from 12m² to 2 000m². Generally, the supply pipes should be laid underground, however, due to various technical reasons, alternative installation methods may be considered. As for the location and safety separation distance requirement for pipelines, the EMSD (Gas Standards Office) is the authority to advise. No supply pipes should be accommodated in a highway structure which is a sole access or carries a strategic route. However, consideration should be given to waive the constraint when there is no alternative route. Close liaison between the Highways Department (HyD) and the gas company at the early planning stage will be necessary in identifying an acceptable routing arrangement.

Centralized LPG supply Installations

- 3.3.2 A permanent site located within the development areas being served is required. However, the size of the storage area required, the safety distances needed, and the laying of pipes would be subject to advice of the EMSD (Gas Standards Office). As a general rule, the installations should be secure, sited in a well ventilated area and accessible by vehicles for replenishment and emergency service.

Substitute Town/Natural Gas

- 3.3.3 A temporary LPG/Air mix plant could be located in the vicinity of the township or development being served but not necessarily immediately adjacent to it as substitute town/natural gas can be supplied over long distances by underground pipelines. However, the plant should be located in a well ventilated area where other utility services, such as water and electricity are available and accessible by vehicles for replenishment and emergency service. Whilst the gas production installation itself is temporary, the reticulated supply system is permanent and could be connected with the town/natural gas supply subsequently. The location and site area of a LPG/air mix installation will depend on the number of consumers to be served. The number of consumers determines the quantity of LPG to be stored, vaporization and air-mix plant requirements; these in turn determine the safety distances needed between the installation and adjacent buildings and fixed points of ignition. The advice from the EMSD (Gas Standards Office) should be sought.

Hazard Assessments

- 3.3.4 Hazard assessments for gas works, gas holder stations and LPG installations form an integral part of the project evaluation and additional safety measures may need to be incorporated into the design and/or operations of the installations to ensure that the risk posed to the general public is minimized. Reference should be made to the risk guidelines in Chapter 12 and procedures laid down by the Coordinating Committee on Land Use Planning and Control related to Potentially Hazardous Installations should be followed. The EMSD (Gas Standards Office) is the authority for such hazard assessments. The Land Authority shall notify the gas company concerned of any development (permanent or temporary) that is proposed within a distance of 3m either side of a high pressure (up to 35 bar) gas pipelines.

4. Telephone Service

4.1 General

- 4.1.1 Local fixed telephone service is one of the local fixed telecommunications network services (FTNS). The local FTNS licensees are PCCW-HKT Telephone Limited (PCCW-HKT), Hutchison Global Crossing Limited

(HGC), New T&T Hong Kong Limited (New T&T) and New World Telephone Limited (NWT).

- 4.1.2 International telephone service is one of the external telecommunications services (ETS). The FTNS licences of PCCW-HKT, HGC, New T&T and NWT have been amended to provide non-exclusive ETS. In mid-2001, about 200 companies were awarded the Public Non-exclusive Telecommunications Services Licence to provide ETS.

4.2 Telephone Network

- 4.2.1 A telephone network comprises subscriber premise apparatus, subscriber lines, telephone exchanges and junction circuits.
- 4.2.2 Each subscriber premise apparatus is connected by a pair of subscriber lines to a local telephone exchange where switching and connection are conducted between two subscribers.
- 4.2.3 From the input telephone number, the switching equipment in the telephone exchange will locate the called party who may be in the same exchange or in another exchange.
- 4.2.4 The communication links provided between exchanges are junction circuits which are to carry inter-exchange calls. The junction circuits consist of Telephone Cables Systems and Radio Telecommunication Systems.

4.3 Telephone Exchanges

- 4.3.1 Generally, all telephone exchanges accommodate local exchange equipment. In some telephone exchanges, there may be other types of exchange equipment serving different functions of tandem, toll or other services. Local and tandem exchanges are more common.

(a) Local Exchange

Local exchange is where subscriber lines are terminated. Each local exchange serves its nearby communities. Depending on geographical situations, the density of population and business, the number of subscriber lines served by a local exchange may vary from a few hundreds to 120 000. There are about 90 local exchanges in mid-2001.

(b) Tandem Exchange

Tandem exchanges are employed to relay telephone calls between local exchanges. They are usually co-sited with local exchanges.

4.4 Guidelines on Provision

- 4.4.1 In order to meet demand for telephone service in a new town or redeveloped area on time, the FTNS operators should be advised of the scale of development at an early planning stage. The FTNS operators will investigate if telephone service can be provided from an existing local exchange, by any other methods or a new exchange is required.

Telephone Exchange

- 4.4.2 No direct standard can be derived for land reservation as the size of site varies with a number of factors such as the number of lines and type of switching equipment. However, the following can be adopted as general guidelines:
- (a) For local exchanges in rural areas with less than 10 000 lines, a site area of about 500m² is required.
 - (b) For local exchanges in urban areas with 20 000 to 60 000 lines, a site area between 1 000m² to 1 500m² is required.
 - (c) For local exchange in urban areas with up to 120 000 lines, or combined local/tandem exchanges or telephone exchanges complexes (operator center, office, computer room, exchange), a site area ranging from 1 500m² to 2 000m² is required.
- 4.4.3 In rural areas, small telephone exchanges with land reserved for minor expansion are preferred to large ones so as to preserve the rural amenity.
- 4.4.4 In urban areas, telephone exchanges are normally installed in specially designed multi-storey buildings. However, in exceptional cases, they can be accommodated within other types of buildings with the specific telephone exchange requirements incorporated into the building design.
- 4.4.5 Exchanges need to be located as near as possible to the centre of telephone service demand for efficiency and economic reasons.
- 4.4.6 Exchanges should be provided with easy access to main roads for external cable plant construction and equipment delivery. A corner site abutting two to three roads in rectangular shape is preferable for better cable duct laying and equipment layout. With respect to the access, parking and loading/unloading arrangements, Transport Department should be consulted at an early planning stage.
- 4.4.7 In general, the site should be available for the construction of the telephone exchange about 2.5 years before the completion of the first phase of major developments. This is to ensure availability of telephone service to the users of the initial phases of development.

- 4.4.8 Exchanges should be sited at least 200m from any power generating station, bulk in feed substation or primary substation (i.e. at 132kV or higher voltage) to avoid the risk of rise-of-earth potential and electrical interference which can be very critical to the safety of the operation personnel and to the sophisticated electronic telecommunication installations in the exchanges.
- 4.4.9 Telephone exchanges should be sited away from an electrified rail system, large box culvert, mullah and cable tunnel so as to avoid blockage to the multiway telephone cable lead-in ducts. The separation distance should be assessed on individual basis. FTNS operators should be consulted at an early planning stage.
- 4.4.10 Telephone exchanges should be located away from any dangerous goods installation such as petrol filling station and inflammable material store to avoid the risk of fire or explosion. Moreover, they should not be located near rivers or lakes to avoid flooding problems.

Telephone Cables

- 4.4.11 Telephone cables should normally be laid in underground ducts except where prohibited by other factors such as crossing bridges, rivers and nullahs; temporary cable provision for construction sites; provision of small quantity of overhead cable in rural area due to economical reason and provision of overhead cable over privately-owned land.
- 4.4.12 Telephone cables should be placed as far as possible away from power generating or transformer stations except those feeding the stations. Such telephone cables may require special protection.
- 4.4.13 Telephone cables should be separated as far as possible from power cables. The normal separation should be at least 0.3m. For details, the “Code of Practice - Protection of Communication Network From Electrical Power Distribution” issued by DG, OFCA should be referred to.
- 4.4.14 Telephone cables should be laid as far as possible away from electrified rail systems. In Light Rail Transit System, a minimum separating distance of 2.5m from the nearest rail is required. For Kowloon Canton Railway System, a minimum distance of 300m is required.
- 4.4.15 In principle, highway utilities reserves should be used to carry telephone cable ducts. Consultation with FTNS operators is required in an early planning stage of the highway.

Radio Telecommunication Systems

- 4.4.16 Microwave Radio Communication Systems may be used to connect urban areas to the non-urban areas where the use of telephone cables is impracticable or not economical.
- 4.4.17 They are normally installed on roof top of telephone exchange buildings. However, in exceptional cases, they can also be installed in mobile containers located in the vicinity of the telephone exchange, or installed by other methods.
- 4.4.18 In principle, the aerial equipment needs to be situated in a location which can maintain a clear line-of-sight with the counterpart aerial equipment located at another telephone exchange building or a hill-top radio station.

5. Radio Telecommunications and Broadcasting Services

5.1 General

- 5.1.1 The wide range of facilities within this category makes it impossible to lay down standard land requirements, and they have to be considered on a case-by-case basis. As a general principle, sharing use of existing hill top sites would be encouraged.
- 5.1.2 For radio telecommunications services and broadcasting services delivered by wireless means, OFCA would strive to avoid, as far as possible, the use of virgin hill-top sites, especially the sensitive or high landscape value areas within such sites. In case a new development area cannot be served adequately by radio telecommunications or broadcasting stations installed at the existing hill-top sites, virgin hill-top sites will be necessary. Under such circumstances, the radio telecommunications or broadcasting stations should be located close to the existing access roads as far as possible so as to minimize the need of constructing haul roads which may have adverse impacts to the environment. Given that the process of an application for a virgin hill-top site requires the coordination of multiple government departments, planning for radio telecommunications and wireless broadcasting services in a new development area will have to start at the early planning stage and the lead time may take as long as 36 months.

5.2 Guidelines on Provision of Hill-top Facilities

- 5.2.1 The location and design of telecommunications and broadcasting structures (e.g. buildings and towers) should be determined with reference to the “Procedure for Applications to Use or Develop Hill-top and Rural Sites for Radio-telecommunications Systems” which is issued by OFCA and is available upon request.

6. Water Supply

6.1 General

- 6.1.1 Approximately 70-80% of the fresh water consumed in Hong Kong is obtained from Mainland via the agreement made with the Guangdong Authority. The remaining 20-30% is collected from gazetted water gathering grounds which occupy about one-third of the total area of the territory.
- 6.1.2 The principal land requirements for fresh water supply are those for storage reservoirs and water gathering grounds, water conduits, water treatment works, pumping stations, service reservoirs, depots, workshops and offices. Land is also required for conduits, pumping stations, and service reservoirs for the supply of salt water for flushing.
- 6.1.3 Land in water gathering grounds needs not be used exclusively for water supply and there are agreed policies by which other compatible uses may be permitted. Planning of development or projects to be located inside or near the water gathering grounds should follow guidelines laid down by Water Supplies Department (WSD). These are set out in the “Working Party Report on Land Use and Development in Catchment Areas”. Amongst such other uses are notably Country Parks, Special Areas or Sites of Special Scientific Interest, and other recreational areas, etc.
- 6.1.4 The occupation of seafront land by water supply utilities that will result in environmental and visual impacts should be avoided. Unless justified on operational grounds, or when there is no better alternative location, relevant bureaux/departments should keep the footprint of the facility to a minimum as far as possible, and implement necessary mitigation measures to reduce impact on the waterfront. Where practicable, relevant bureaux/departments should also proactively set back boundary of the facility to provide waterfront passageway for public use.
- 6.1.5 Roofs of service reservoirs in most cases provide large level surfaces. Where they are easily accessible from nearby populated areas and are not required by the WSD for operational reasons, they can be planned for open spaces, recreation grounds and other compatible uses subject to proper management and appropriate safeguards. The intention for this dual use should be agreed with the WSD before designing a service reservoir.

6.2 Locational Guidelines

6.2.1 *Service Reservoirs*

- (a) Service reservoirs (both fresh water and salt water) should be located as near as possible to the area they served and, wherever possible, sited at a level where water can be fed by gravity to the Supply Zone. The location should avoid, as far as possible, country parks, prominent seafront areas, special areas and other environmentally sensitive areas.
- (b) Where possible, difficult sites should be avoided so as to minimize the construction costs. The design of the reservoirs should reduce adverse visual, landscape, and ecological impacts. Landscape treatments should be incorporated in the design.
- (c) Where alternative sites are available, all of which satisfy waterworks requirements (construction costs, operation costs, etc.), it is desirable to choose sites which are more accessible so that the roofs can be used for recreation.

6.2.2 *Pumping Stations*

- (a) They should normally be located within reasonable proximity to the source of supply to ensure a positive suction head is available.
- (b) Sites for pumping stations should have adequate vehicular access to facilitate maintenance and transportation of materials and dangerous goods (disinfectant substances, etc.).
- (c) Pumping stations should be located away from residential or other sensitive uses, wherever possible, to minimize noise problems. If this is not feasible, suitable control measures will need to be included in the design of the stations (see also Section 4.2.13 of Chapter 9). If necessary, landscaping should also be incorporated to blend in with the surrounding environment.
- (d) Salt water pumping stations for intake of seawater should be located as near as possible to seafront with access to a source of clean sea water. It is necessary that marine activities and drainage outfalls are kept away from the sea water intake of the stations. A minimum clear distance of 100m (i.e. 200m being the total distance of the two sides from the intake point) is normally required. The footprint of any salt water pumping stations located by the waterfront should be kept to a minimum as far as practicable. The environmental and visual impact of the pumping station on the waterfront should be reduced through incorporation of suitable mitigation measures, and the design of the pumping station should integrate with the adjoining waterfront promenade.

6.2.3 *Water Treatment Works*

- (a) For water treatment works classified as Potentially Hazardous Installation, their locations should comply with the procedures laid down by the Coordinating Committee on Land Use Planning and Control related to Potentially Hazardous Installations (CCPHI).
- (b) Locations of water treatment works should take account of the possible environmental impacts arising from sludge discharge, noise from pumping facilities (see para. 6.2.2 (c) above), and physical appearance. Any sludge discharge must comply with the established guidelines for effluent control while suitable landscaping should also be incorporated, where necessary, to blend in with the surrounding environment.

6.2.4 *Water Mains*

- (a) Water mains are normally placed underground and routed along carriageways. Where circumstances permit, they should best be routed beneath separate reserves, like pedestrian ways or cycle tracks. Amenity strips should be avoided unless under necessary circumstances.
- (b) Adequate separation of water mains from power cables and other services should be allowed, wherever practicable.
- (c) It is bad engineering practice to route water mains close to the crest of a slope. All possible steps must be taken to prevent leakage affecting the stability of the slope. As a general rule, all water mains should not be placed in a slope nearer to the crest of the slope than a distance equal to its vertical height. This is a minimum standard, but each case should be considered on its own merits. In cases where the proposed development cannot be modified to permit the siting of water mains outside this crest area, the slope should be designed to the appropriate factors of safety, taking into account the effects of possible water leakage. As an alternative, water mains can be housed within a sealed trench, ducting system or sleeve drained to a suitable discharge point at a surface drain or natural stream. The ducting system should be designed with a drainage capacity equivalent to a pre-determined leakage rate. It is recommended that discharge from the ducting system be monitored at six monthly intervals.

7. Drainage Services

7.1 General

7.1.1 Drainage services include the provision, operation and maintenance of foul sewerage, sewage treatment and disposal, and stormwater drainage infrastructures. Public drainage services are currently provided by the Drainage Services Department.

7.1.2 The provision of such services, whether for public or private use, shall conform with the standards and guidelines for environmental planning as set out in Chapter 9.

7.2 Foul Sewerage System

7.2.1 Sewage should be collected and conveyed in enclosed foul sewers which should normally be placed underground. Sewerage system should be designed to minimize odour and septic problems. For operation and maintenance requirement for septicity control, users may refer to the relevant Drainage Services Department Practice Notes No. 1/2011 – Design Checklists on Operation & Maintenance Requirements.

7.2.2 Sewers could be located under the carriageways, footpaths or cycle tracks. Amenity strips should be avoided unless under necessary circumstances. If this is not feasible, separate drainage reserves should be provided. The location and alignment of a sewer should be chosen such that, during the subsequent maintenance of the sewer, disruption to vehicular and pedestrian traffic is minimized. Where sewers are placed under carriageways, they should be located within one traffic lane as far as possible to minimize disruption to traffic during maintenance. Gravity sewerage systems should be used as far as possible.

7.3 Stormwater Drainage System

7.3.1 Stormwater may be collected and conveyed either in enclosed drains or open channels. Section 7.2.2 is also applicable to the planning and design of enclosed stormwater drains. New drainage channels/systems should adopt environmental and sustainable design as far as practicable. For design of drainage infrastructure including green river channels and flood mitigation/retention measures, users may refer to the relevant Drainage Services Department Practice Note No. 1/2005 – Guidelines on Environmental Considerations for River Channel Design.

7.3.2 When choosing the alignment of drainage channels, account should be taken to minimize disruption to adjacent communities and minimize land resumption.

- 7.3.3 Supporting facilities such as vehicular access should be provided to enable proper operation and maintenance of the drainage channels. Landscaping should be considered and incorporated to blend in with the environment. Supporting drainage facilities such as channel embankments may be permitted to be used as amenities or recreational areas and access roads as waterfront promenades.

7.4 Pumping Stations and Sewage Treatment Works

- 7.4.1 Sewage treatment works and stormwater and sewage pumping stations should be designed to minimize noise, odour and visual problems. They should be located away from residential or other sensitive areas by providing suitable buffer zones, where possible. If this is not feasible, suitable abatement measures such as acoustic insulation, odour control and landscaping should be included in the design of the facilities. If there are operational needs for the pumping station to be located at prominent waterfront areas, the footprint should be minimized as far as practicable, with landscaping and enhancement works carried out to reduce its environmental and visual impacts. Sewage pumping stations and the associated rising mains, and sewage treatment works should also be designed to minimize unintended prolonged retention of sewage and formation of septic conditions.

7.5 Polder Drainage and Stormwater Pumping Schemes

- 7.5.1 Polder drainage and stormwater pumping schemes are to render flood protection to buildings and houses in low-lying areas. The scheme entails the construction of stormwater pumping station, stormwater storage pond, and flood protective bund or wall around the buildings and houses and stormwater storage pond.
- 7.5.2 Stormwater storage ponds should be located at the lowest areas of the schemes. They should either be covered or properly fenced off for safety reasons. Under no circumstances should public access routes be allowed through the areas of the stormwater storage ponds.

7.6 Drainage Reserves

- 7.6.1 Unrestricted vehicular access to Drainage Reserves should be provided at all times. Structures of any kind should generally not be permitted unless in exceptional circumstances. Besides, planting proposals involving extensive and deep root plants within Drainage Reserves should seek Drainage Services Department's endorsement before implementation.

8. Dedicated Utility Reserves

- 8.1 In general, utilities will not be permitted within the boundaries of an expressway, unless they are essential to its operation e.g. street lighting and emergency telephones etc.. Other utilities may be permitted in exceptional circumstances with the agreement of the Director of Highways. In the planning of new development areas, provision should be made for dedicated utility reserves on the road side pavements, such as pedestrian walkways and cycle tracks etc. for the laying of various utilities such as electricity and telephone cables, gas, sewers, drains and water pipes etc. Whenever practicable, dedicated utility reserves should preferably be outside road reserves. Such arrangement would help reducing possible disruption to vehicular traffic during maintenance periods. Laying utilities on amenity strips should be avoided unless under necessary circumstances.
- 8.2 Adequate separation between different kinds of utility provisions shall be allowed for in the dedicated reserves. The actual width of the reserves will vary depending on individual circumstances and the types of utilities to be accommodated. Early consultation with the relevant utility companies and concerned departments at the planning stage will be necessary.
- 8.3 For underground services and installations, sufficient cover should be provided. The minimum depth requirements for underground services and installations are stipulated by HyD, details of such requirements are stated in the standard conditions of Excavation Permit promulgated by Highways Department and accessible from the HyD's Homepage (<http://www.hyd.gov.hk>). Early consultation with HyD at the planning stage will be necessary.

9. District Cooling System

9.1 General

- 9.1.1 The provision of utility services is fundamental to modern living. They are essential components of the basic infrastructures and have important roles in combating climate change. To prepare for the global urban challenge, it is imperative to embrace the smart, green and resilient principles in the planning and design of utility services. The development of new utility services should focus on sustainable planning and urban design, promote low-carbon and energy efficient infrastructure, enhance climate resilience and minimise demand for use of resources. District Cooling System (DCS) is a low-carbon and energy efficient infrastructure that could reduce heat island effect and contribute to the development of Hong Kong into a low-carbon city. It is the Government's policy to formalise the requirement to consider the development of DCS at the early stage of planning and development for large scale new development areas (NDAs) and redevelopment areas (RAs) where a larger number of potential consumer buildings could be identified to support the DCS.

- 9.1.2 This set of Guidelines is intended for DCS development carried out by Government as public project. For DCS development carried out by other bodies or private enterprises, the project proponents are suggested to consult the Environment Bureau (ENB) and Electrical and Mechanical Services Department (EMSD) at the early planning stage.
- 9.1.3 A DCS is a centralised air-conditioning system producing and distributing chilled water to consumer buildings in NDAs or RAs through a system of closed loop network of underground pipes for air-conditioning purpose (Diagram below).

Network of District Cooling System

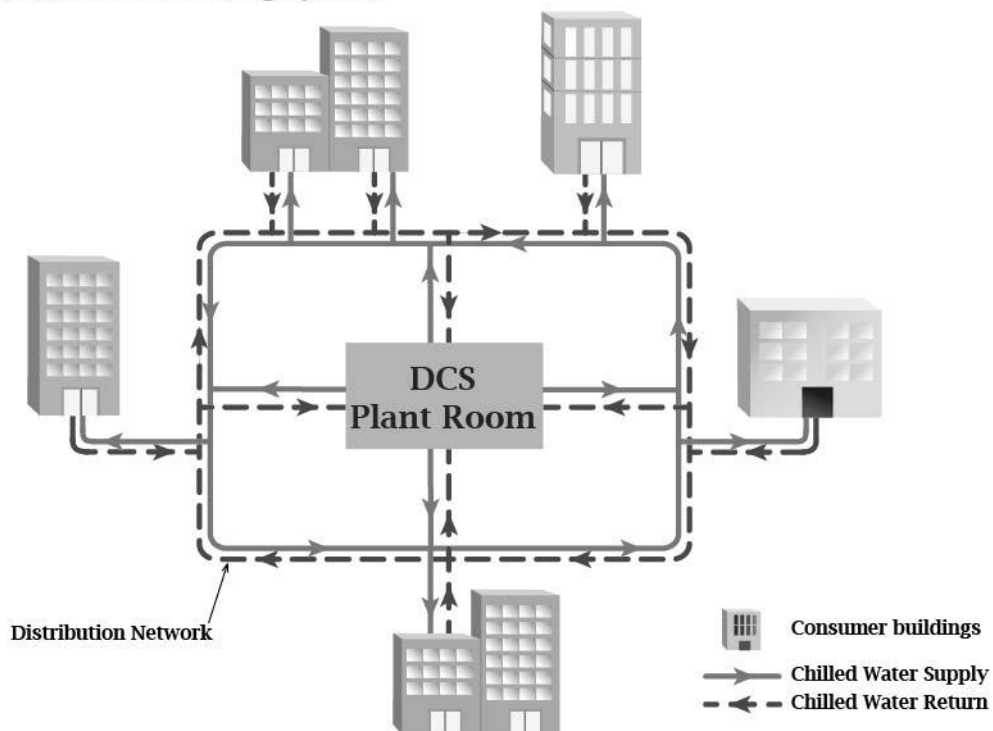

Diagram: Network of District Cooling System

9.2 General Guidelines on Provision

The following sets out key planning and design guidelines for considering the feasibility of developing DCS at the early stage of planning and development for NDAs or RAs:

Locational Requirements

- 9.2.1 The supply of water for the production of chilled water is a prerequisite requirement for DCS. Given that seawater should be used due to energy efficiency consideration, the DCS plant room should preferably be located close to the seashore to minimise the length of seawater pipework or culvert length. The reservation and availability of site near seashore with convenient access to seawater would be essential. Nevertheless, other water supply can be considered subject to technical assessment.

- 9.2.2 A DCS plant room should be close to its targeted consumer buildings in order to minimise the cost of laying chilled water distribution pipes and to achieve the maximum effect of energy efficiency. As a general guideline, the EMSD has recommended that the distance of targeted consumer buildings away from the DCS plant room should normally not be more than 2,000m.

Site Requirements and Configurations

- 9.2.3 For cost-effective operation reason, the minimum site area required for a standard DCS plant room is 5,400m² with a typical dimension of 180m x 30m to serve a cooling demand capacity of about 40,000TR (refrigeration ton). The exact site requirement would depend on the scale of development that is served by the DCS and should be determined in consultation with EMSD.

Other Criteria and Considerations

- 9.2.4 A DCS requires significant cooling demand for being an efficient and cost-effective alternative to conventional air-conditioning systems. In general, DCS will only provide chilled water to non-residential developments since residential developments normally will not adopt central air-conditioning system which is the prerequisite requirement for using DCS. In this connection, EMSD recommends that, in general for planning purposes, there should be a total of 200,000m² of non-residential air-conditioning floor area⁽⁵⁾ from all targeted consumer buildings in the NDAs or RAs to warrant a standard DCS to be financially sustainable.
- 9.2.5 Since land is a very scarce resource in Hong Kong and there are many competing land uses to meet various demand in our community, DCS plant room should preferably be located underground to save the above-ground of the site for other compatible beneficial land uses. It is technically feasible for DCS plant room to be located underground such as beneath a park or playground for most of its components. Sufficient openings for access should be allowed for operation and maintenance purposes. However, in case of using cooling towers as the heat rejection method (due to seawater not available for heat rejection), above ground structure is required for installation of these cooling towers. The bulk and height of these above ground structures supporting the DCS should be minimized as far as practicable so that the design of such structures could blend into the surroundings.
- 9.2.6 Standalone / detached DCS plant room should be avoided as far as possible to optimise land use efficiency, and it should be located in areas with minimal development potential as far as possible. Co-location of

⁽⁵⁾ It may be possible to provide DCS services to residential buildings served by central air-conditioning subject to request and availability of spare capacity.

DCS plant room with other compatible uses should also be considered. DCS plant room can be made to integrate with plant room of other infrastructures such as drainage facilities, pumping facilities and flyovers. Other uses suitable for co-location include uses that are comparatively less sensitive to noise and vibration and with suitably designed mitigated measures. For example, these might include public open space, public car park, Government workshop/storage, public market, etc. Furthermore, for joint user building development, DCS plant room is preferably to be accommodated in the basement or on ground floor of a building as transportation of heavy cooling equipment to higher floors may impose difficulties to operation and maintenance of the DCS plant room.

9.3 Considerations at Planning and Implementation Stages

The policy decision of whether a DCS should be developed in NDAs or RAs rests with ENB while EMSD would provide technical advice and support to ENB. The feasibility of DCS in NDAs or RAs should be explored in the context of Planning and Engineering (P&E) studies for NDAs or RAs. For development of individual DCS outside the context of P&E studies for NDAs or RAs, EMSD should provide technical advice and support to ENB, conduct detailed feasibility studies on DCS for confirming the technical feasibility required for the creation of a new Public Works Programme item. The following technical issues should be addressed in the study process:

Environmental Impact Considerations

- 9.3.1 The environmental impacts of a DCS should be assessed in the context of Environmental Impact Assessment (EIA) for NDA or RA if the NDA or RA falls within Schedule 3 major designated projects requiring EIA under the EIA Ordinance (Cap.499).
- 9.3.2 Water discharges from DCS plant room may have adverse impacts on the ecology, fisheries and water quality etc. and hence, relevant environmental assessments such as water quality and air quality impact assessments will need to be conducted.
- 9.3.3 As the operation of DCS plant room might generate nuisance to the sensitive receivers in the vicinity and also to other joint-users, assessment on the relevant impacts including nuisance affecting the co-users should be conducted. Appropriate mitigation measures should be proposed to meet the statutory requirements and planning standards, if applicable, and minimise the nuisances to any sensitive receivers especially those building occupants that are sensitive to noise, vibration, humidity etc.

Urban Design Guidelines

- 9.3.4 For any above ground structures supporting the DCS plant room, in particular those close to the waterfront/seashore, visual and urban design concerns should be observed. The design should be responsive to the

waterfront setting, and avoid creating visual and physical barrier to the open water and disruption to the continuous waterfront promenade. Suitable mitigation measures such as background-compatible design and landscaping should be incorporated. The bulk and height of any above ground structures supporting the DCS should be minimised. Greening opportunities should be explored as far as possible. Reference can be made to the good design principles for waterfront sites in the Urban Design Guidelines – Chapter 11 of the HKPSG.

Technical Guidelines

- 9.3.5 Reference should be made to the EMSD guidelines on “Technical Guidelines for Connection to District Cooling System”, which sets out the general principles and requirements to be applied to the design and installation works required for connection to DCS, e.g. substation. The document is available on the website of EMSD (www.emsd.gov.hk). Early consultation with EMSD at the planning stage is recommended.
- 9.3.6 Proponents of DCS should follow the relevant statutory and administrative procedures/requirements as appropriate at the implementation stage.

Figure 1 Preferred Working Corridor and Minimum Safety and Vertical Ground Clearance

For 400kV System

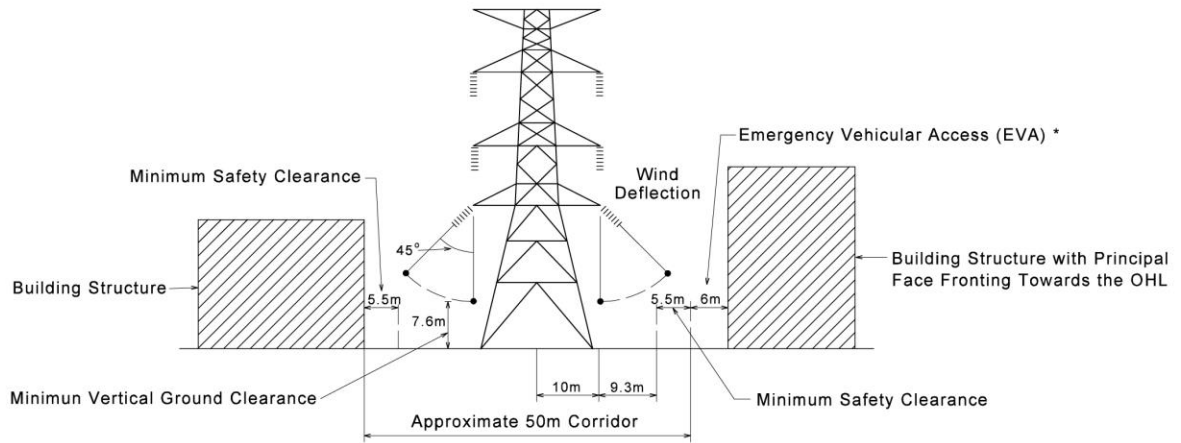

* : Optional requirement subject to FSD's advice

Figure 2 Span Elevation of 400kV OHL

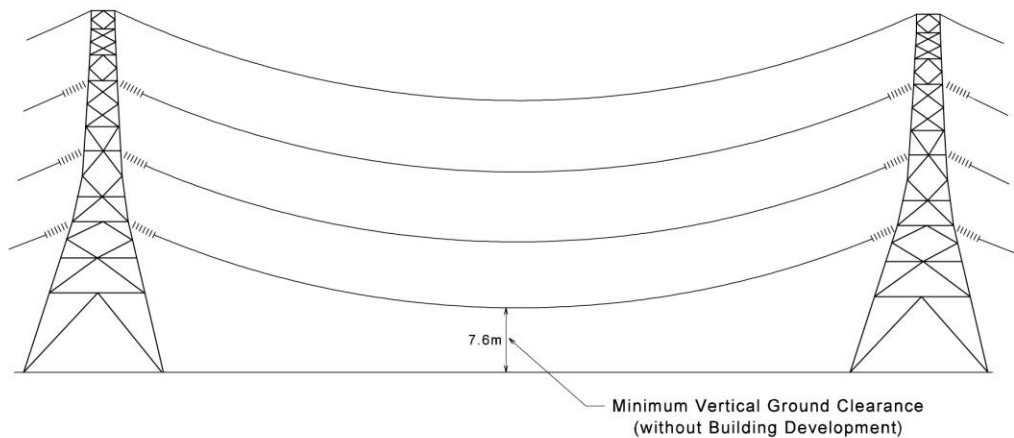

Source : CLP Power Hong Kong Limited

Figure 3 Preferred Working Corridor and Minimum Safety and Vertical Ground Clearance

For 132 kV System (Tower Line)

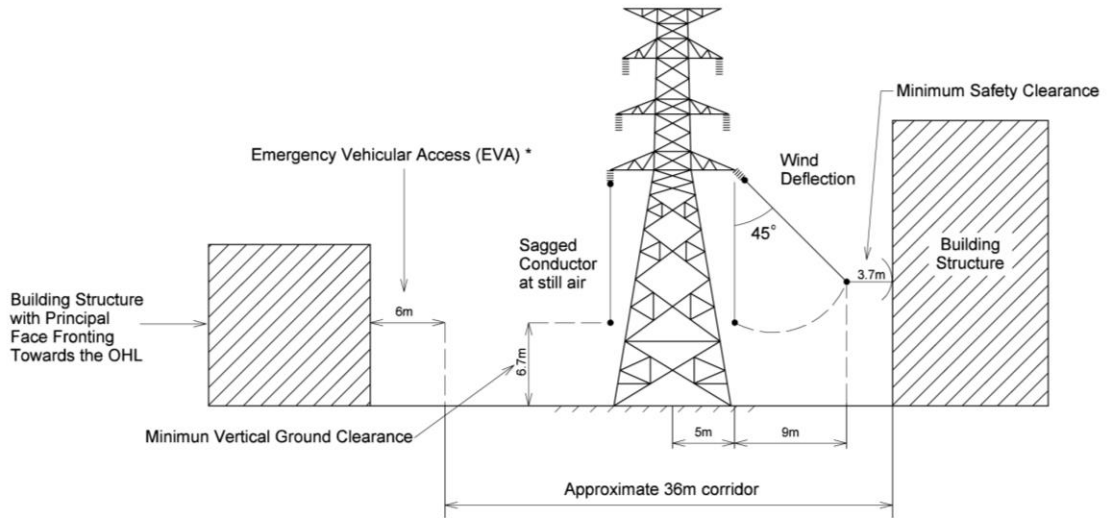

* : Optional requirement subject to FSD's advice

Figure 4 Span Elevation of 132kV OHL

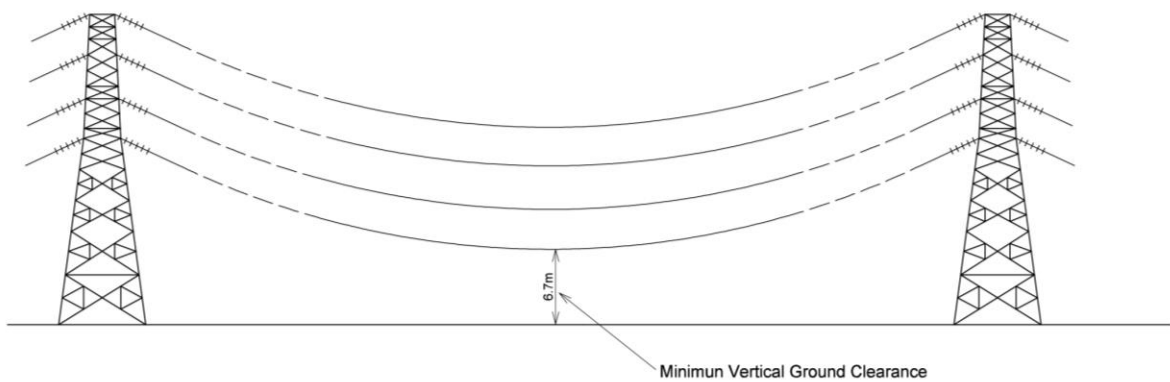

Source : CLP Power Hong Kong Limited

Figure 5 Plan View of Preferred Working Corridor and Minimum Safety Clearance for 132kV Pole Line

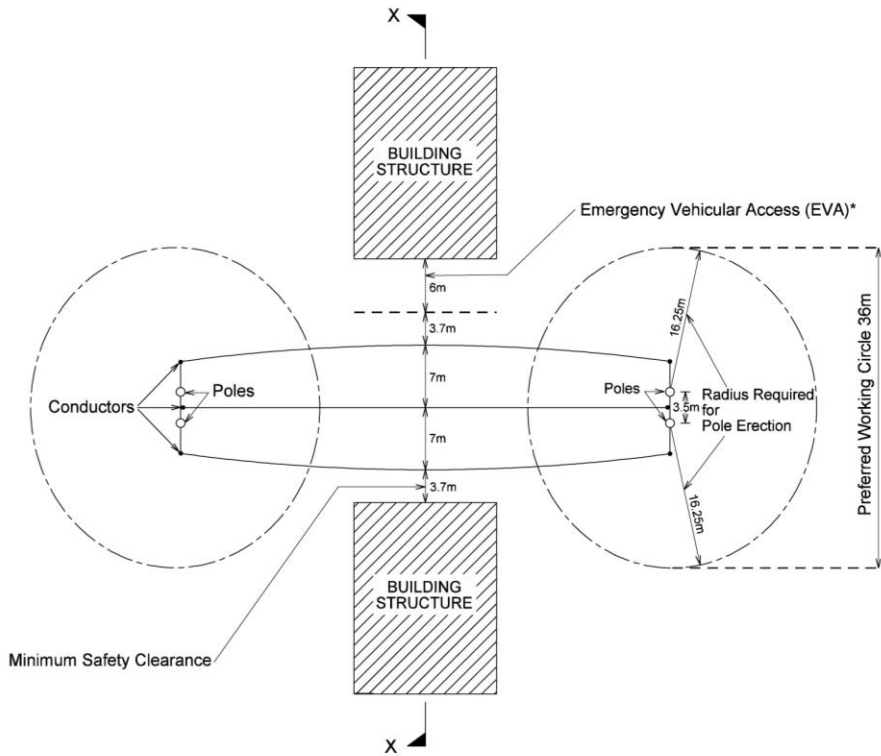
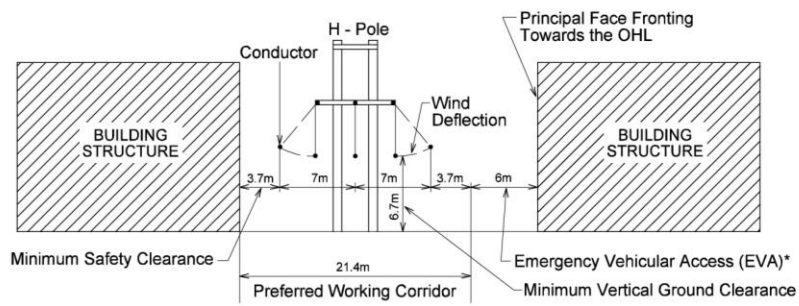

Figure 6 Minimum Vertical Ground Clearance for 132kV Pole Line



SECTION X-X OF FIG. 5 SHOWING MINIMUM VERTICAL GROUND CLEARANCE FOR 132kV POLE LINE

* : Optional requirement subject to FSD's advice

Source : CLP Power Hong Kong Limited

Figure 7 Schematic Drawing Showing Possible Village Type House Development Underneath 400kV OHL

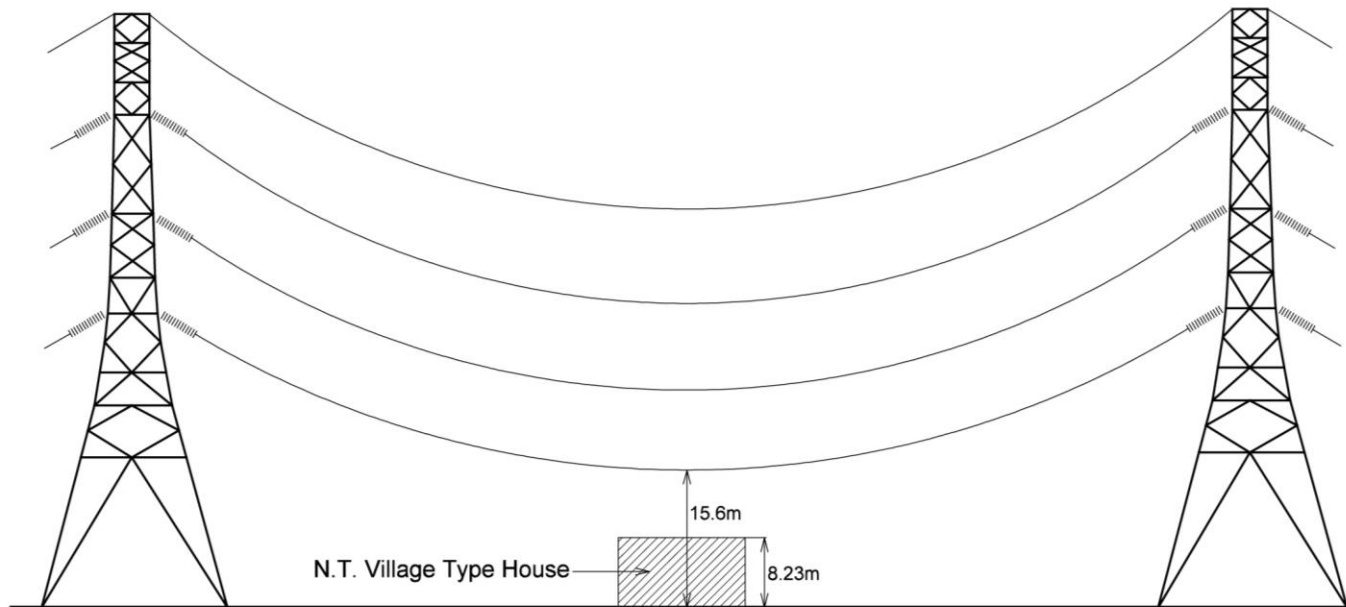

Source : Modified on the basis of CLP Power's drawing